

1 Description

The SY6105 is a 1.04A highly integrated single cell linear battery charger IC with power path management for wearable and IoT devices using Li-ion/Li-Polymer batteries. The I²C serial interface with charging and system setting can be allowed to be controlled flexibly.

The SY6105 can automatically complete charger phase include pre-charge, fast charge, charge termination. Also monitor battery temperature during charging. Power path management will provide higher priority system load even with depleted battery.

The device owns full system reset, include watchdog and PWRKEY reset, also supports ship mode to save power consumption.

The SY6105 is available in a 1.45x1.45mm, 9-ball / 0.5-pitch CSP package and DFN2x3-8L package.

2 Application

IoT device

Smart watches

BT headsets/TWS earbuds

3 Features

- ◆ Linear Single Cell Battery Charger
 - ±0.5% charger voltage regulation@25°C
 - 28V maximum input voltage rating
- Low to 1mA terminal current with 2mA step
- Pre charge current supports quadruple setting
- ITERM supports supports double setting
- Max charging current reach to 1.04A linear charger
- Default 4.65V system voltage regulation, max to 4.85V
- Support safety timer during charging
- Support battery NTC detection
- ◆ Power Path Management
 - Max to 1.2A IINDPM
 - Default 4.6V VINDPM
 - Support Supplement mode from battery during DPM happens
 - Support PWRKEY and COLD Reset
- ◆ I²C interface configure function options
- ◆ Full charging and fault status indication and report to host via INT
- ◆ Full device protection, include OVP / OCP / SCP / OTP
- ◆ Support Ship mode
 - Low to 300nA current
 - Configurable BATFET_DIS delay time
 - Configurable time and action to wake up from ship mode
- ◆ Safety-related certification:
 - IEC62368 CB certification
 - CQC: GB4943.1-2022

4 Typical Application Circuit

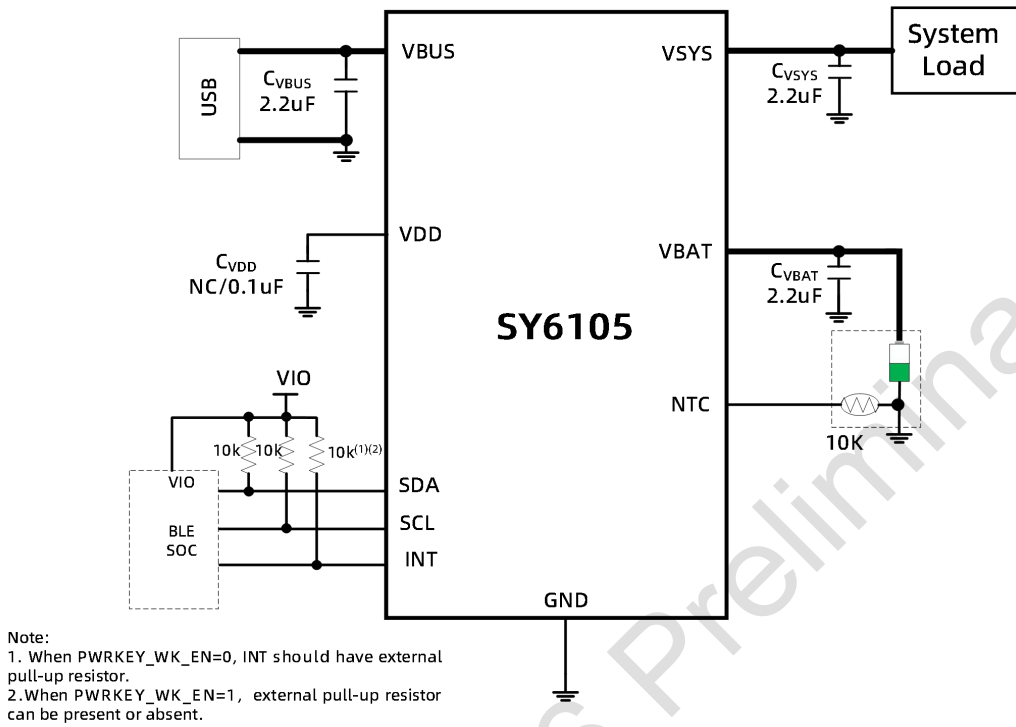

Figure 1. Application Circuit