I2C Controlled 3A Buck Switch Charger with NVDC Power Path Management and OTG Output

1 Description

The SY6206 is a highly integrated 3A switch-mode buck charger for single-cell Li-Ion and Li-polymer batteries, operating with an input voltage range of 4.0-13.5V and 1.5MHz switching frequency. It features NVDC system power path management, which separates the system load and charge current. Additionally, it supports system power-on even with a depleted battery.

The SY6206 can support up to 3A charging current. It initiate and complete charging cycle without host control. The charging profile can be configured through I2C. The step of charge voltage is low to 10mV and the step of charge current is 20mA.

The SY6206 is compatible with the BC1.2 and can automatically set the input current limit based on the input sources type.

The SY6206 integrates an OTG function with 2.4A output capability, which can deliver power from the battery to other devices through a USB port.

The SY6206 reverse operation supports Bypass Mode, which connects battery directly to the PMID pin via BATFET and HSFET. This mode enables extreme efficiency when powering external accessories and maximizes battery runtime.

Integrated high accuracy 12-bit ADC for voltage, current, NTC, die temperature monitoring.

The SY6206 is available in packages of QFN2.5x3-18.

2 Applications

Smart watch/band and other wearable device
Mobile phone, tablet
POS
Portable devices and accessory

3 Features

- ◆ 2.5uA quiescent current in standby mode
- ◆ 0.3uA quiescent current in ship mode
- ◆ High-efficiency switch-mode buck charger
 - Charging current up to 3A
 - >91.5% charge efficiency at 2A@5V
 - >90% charge efficiency at 2A@9V
- ◆ High accuracy charging profile
 - $\pm 0.4\%$ charge voltage regulation
 - $\pm 5\%$ charge current regulation@1.5A
- Low termination current to 10mA
- ◆ Support USB On-The-Go (OTG) mode
 - Adjustable output from 4.6V to 9.52V
 - Up to 2.4A output
 - Soft-start up to 500uF capacitive load
 - Support reverse boost on PMID output
 - Bypass mode on PMID output for extreme efficiency
- ◆ NVDC power path management
 - Support 4.0V to 13.5V input voltage operation
 - Instant-On works with deeply discharged battery
 - Programmable input current limit (IINDPM) and input voltage limit (VINDPM)
- ◆ Safety and protection
 - Protection includes VBUS OVP, battery OVP/OC, boost OVP/OC
 - Charging safety timer
 - Thermal regulation and thermal shutdown
 - IEC62368-1 CB Certificate

4 Typical Application Circuit

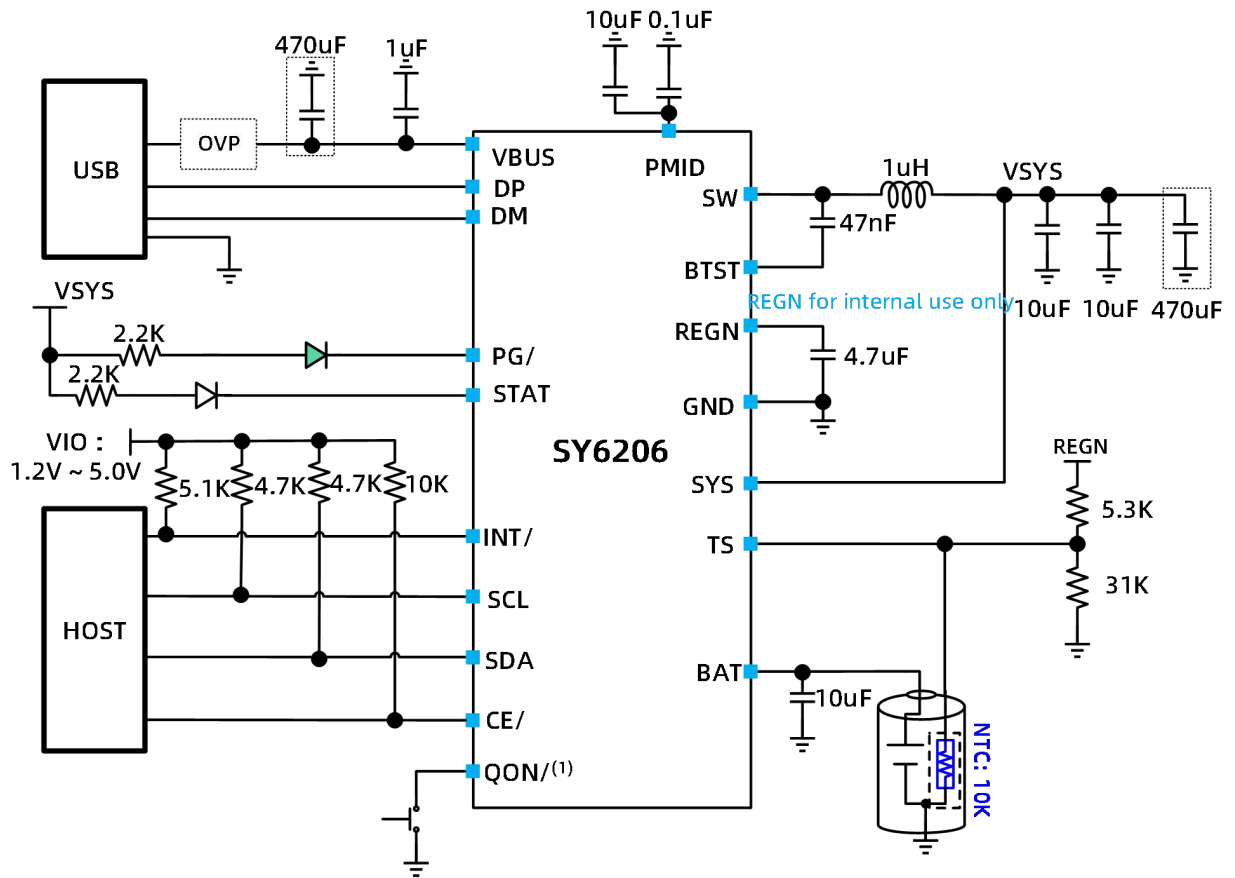

Figure 4- 1. Typical Application Circuit

Note: (1)QON/ has internal pull-up